

XI

IIT-NEET

PHYSICS

FRICION



YOUR GATEWAY TO EXCELLENCE IN
IIT-JEE, NEET AND CBSE EXAMS

N L M-FRICTION

3

BASIC CONCEPTS

FREE BODY DIAGRAM

SOLVED EXAMPLES

PRACTICE SET

PREVIOUS YEAR PROBLEM

CONTACT US:

+91-9939586130

+91-9955930311



NEWTON'S LAWS OF MOTION

friction



If we slide or try to slide a body over a surface the motion is resisted by a bonding between the body and the surface. This resistance is represented by a single force and is called friction.

The force of friction is parallel to the surface and opposite to the direction of intended motion.

5.2 Types of Friction

(1) **Static friction** : The opposing force that comes into play when one body tends to move over the surface of another, but the actual motion has yet not started is called static friction.

(i) If applied force is P and the body remains at rest then static friction $F = P$.

(ii) If a body is at rest and no pulling force is acting on it, force of friction on it is zero.

(iii) Static friction is a self-adjusting force because it changes itself in accordance with the applied force.

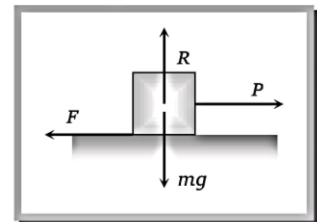

(2) **Limiting friction** : If the applied force is increased the force of static friction also increases. If the applied force exceeds a certain (maximum) value, the body starts moving. This maximum value of static friction upto which body does not move is called limiting friction.

(i) The magnitude of limiting friction between any two bodies in contact is directly proportional to the normal reaction between them.

$$F_l \propto R \text{ or } F_l = \mu_s R$$

(ii) Direction of the force of limiting friction is always opposite to the direction in which one body is at the verge of moving over the other

(iii) Coefficient of static friction : (a) μ_s is called coefficient of static friction and defined as the ratio of force of limiting friction and normal reaction $\mu_s = \frac{F}{R}$

(b) Dimension : $[M^0 L^0 T^0]$

(c) Unit : It has no unit.

(d) Value of μ_s lies in between 0 and 1

(e) Value of μ depends on material and nature of surfaces in contact that means whether dry or wet ; rough or smooth polished or non-polished.

(f) Value of μ does not depend upon apparent area of contact.

(3) **Kinetic or dynamic friction** : If the applied force is increased further and sets the body in motion, the friction opposing the motion is called kinetic friction.

(i) Kinetic friction depends upon the normal reaction.

$$F_k \propto R \text{ or } F_k = \mu_k R \text{ where } \mu_k \text{ is called the coefficient of kinetic friction}$$

(ii) Value of μ_k depends upon the nature of surface in contact.

(iii) Kinetic friction is always lesser than limiting friction $F_k < F_l \quad \therefore \mu_k < \mu_s$

i.e. coefficient of kinetic friction is always less than coefficient of static friction. Thus we require more force to start a motion than to maintain it against friction. This is because once the motion starts actually ; inertia of rest has been overcome. Also when motion has actually started, irregularities of one surface have little time to get locked again into the irregularities of the other surface.

(iv) Types of kinetic friction

(a) **Sliding friction** : The opposing force that comes into play when one body is actually sliding over the surface of the other body is called sliding friction. *e.g.* A flat block is moving over a horizontal table.

(b) **Rolling friction** : When objects such as a wheel (disc or ring), sphere or a cylinder rolls over a surface, the force of friction comes into play is called rolling friction.

□ Rolling friction is directly proportional to the normal reaction (R) and inversely proportional to the radius (r) of the rolling cylinder or wheel.

$$F_{\text{rolling}} = \mu_r \frac{R}{r}$$

μ_r is called coefficient of rolling friction. It would have the dimensions of length and would be measured in *metre*.

□ Rolling friction is often quite small as compared to the sliding friction. That is why heavy loads are transported by placing them on carts with wheels.

□ In rolling the surfaces at contact do not rub each other.

□ The velocity of point of contact with respect to the surface remains zero all the times although the centre of the wheel moves forward.

5.3 Graph Between Applied Force and Force of Friction

(1) Part OA of the curve represents static friction (F_s). Its value increases linearly with the applied force

(2) At point A the static friction is maximum. This represent limiting friction (F_l).

(3) Beyond A, the force of friction is seen to decrease slightly. The portion BC of the curve therefore represents the kinetic friction (F_k).

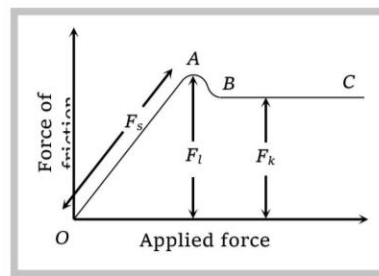

(4) As the portion BC of the curve is parallel to x-axis therefore kinetic friction does not change with the applied force, it remains constant, whatever be the applied force.

5.4 Friction is a Cause of Motion

It is a general misconception that friction always opposes the motion. No doubt friction opposes the motion of a moving body but in many cases it is also the cause of motion. For example :

(1) In moving, a person or vehicle pushes the ground backwards (action) and the rough surface of ground reacts and exerts a forward force due to friction which causes the motion. If there had been no friction there

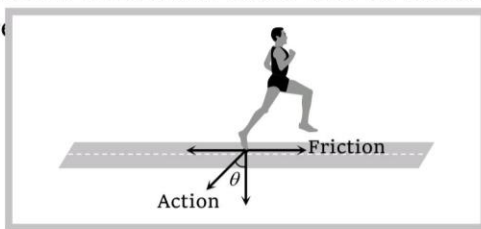

(2) In cycling, the rear wheel moves by the force communicated to it by pedalling while front wheel moves by itself. So, when pedalling a bicycle, the force exerted by rear wheel on ground makes force of friction act on it in the forward direction (like walking). Front wheel moving by itself experience force of friction in backward direction (like rolling of a ball). [However, if pedalling is stopped both wheels move by themselves and so experience force of friction in backward direction.]

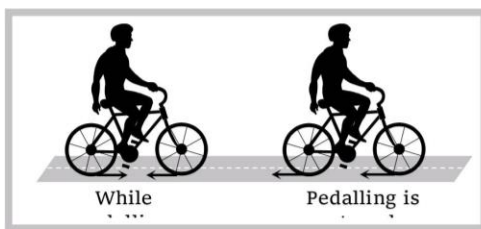

(3) If a body is placed in a vehicle which is accelerating, the force of friction is the cause of motion of the body along with the vehicle (i.e., the body will remain at rest in the accelerating

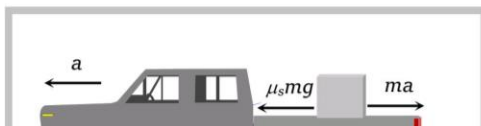

vehicle until $ma < \mu_s mg$). If there had been no friction between body and vehicle the body will not move along with the vehicle.

From these examples it is clear that without friction motion cannot be started, stopped or transferred from one body to the other.

Sample problems based on fundamentals of friction

Problem 1. If a ladder weighing $250N$ is placed against a smooth vertical wall having coefficient of friction between it and floor is 0.3 , then what is the maximum force of friction available at the point of contact between the ladder and the floor

- (a) $75 N$ (b) $50 N$ (c) $35 N$ (d) $25 N$

Solution : (a) Maximum force of friction $F_f = \mu_s R = 0.3 \times 250 = 75 N$

Problem 2. On the horizontal surface of a truck ($\mu = 0.6$), a block of mass $1 kg$ is placed. If the truck is accelerating at the rate of $5m/sec^2$ then frictional force on the block will be

- (a) $5 N$ (b) $6 N$ (c) $5.88 N$ (d) $8 N$

Solution : (a) Limiting friction $= \mu_s R = \mu_s mg = 0.6 \times 1 \times 9.8 = 5.88 N$

When truck accelerates in forward direction at the rate of $5m/s^2$ a pseudo force (ma) of $5N$ works on block in back ward direction. Here the magnitude of pseudo force is less than limiting friction So, static friction works in between the block and the surface of the truck and as we know, static friction = Applied force = $5N$.

Problem 3. A block of mass $2 kg$ is kept on the floor. The coefficient of static friction is 0.4 . If a force F of $2.5 N$ is applied on the block as shown in the figure, the frictional force between the block and the floor will be [MP PET 2000]

- (a) $2.5 N$
(b) $5 N$
(c) $7.84 N$
(d) $10 N$

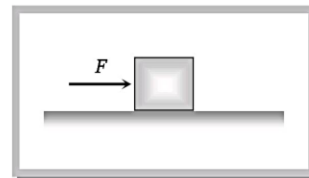

Solution : (a) Applied force = $2.5 N$ and limiting friction $= \mu mg = 0.4 \times 2 \times 9.8 = 7.84 N$

As applied force is less than limiting friction. So, for the given condition static friction will work.

Static friction on a body = Applied force = $2.5 N$.

Problem 4. A block A with mass 100 kg is resting on another block B of mass 200 kg. As shown in figure a horizontal rope tied to a wall holds it. The coefficient of friction between A and B is 0.2 while coefficient of friction between B and the ground is 0.3. The minimum required force F to start moving B will be [RPET 1999]

- (a) 900 N
(b) 100 N
(c) 1100 N
(d) 1200 N

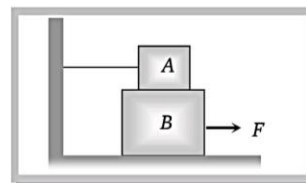

Solution : (c) Two frictional force will work on block B.

$$F = f_{AB} + f_{BG} = \mu_{AB}m_Ag + \mu_{BG}(m_A + m_B)g$$

$$= 0.2 \times 100 \times 10 + 0.3 (300) \times 10$$

$$= 200 + 900 = 1100N. \text{ (This is the required minimum force)}$$

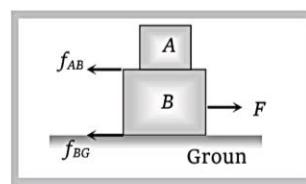

Problem 5. A 20 kg block is initially at rest on a rough horizontal surface. A horizontal force of 75 N is required to set the block in motion. After it is in motion, a horizontal force of 60 N is required to keep the block moving with constant speed. The coefficient of static friction is

(a) 0.38 (b) 0.44 (c) 0.52 (d) 0.60

Solution : (a) Coefficient of static friction $\mu_s = \frac{F_l}{R} = \frac{75}{20 \times 9.8} = 0.38$.

Problem 6. A block of mass M is placed on a rough floor of a lift. The coefficient of friction between the block and the floor is μ . When the lift falls freely, the block is pulled horizontally on the floor. What will be the force of friction

(a) μMg (b) $\mu Mg/2$ (c) $2\mu Mg$ (d) None of these

Solution : (d) When the lift moves down ward with acceleration 'a' then effective acceleration due to gravity

$$g' = g - a$$

$$\therefore g' = g - g = 0 \text{ [As the lift falls freely, so } a = g]$$

So force of friction = $\mu mg' = 0$

5.5 Advantages and Disadvantages of Friction

(1) **Advantages of friction**

- (i) Walking is possible due to friction.
(ii) Two body sticks together due to friction.
(iii) Brake works on the basis of friction.
(iv) Writing is not possible without friction.



(v) The transfer of motion from one part of a machine to other part through belts is possible by friction.

(2) Disadvantages of friction

(i) Friction always opposes the relative motion between any two bodies in contact. Therefore extra energy has to be spent in over coming friction. This reduces the efficiency of machine.

(ii) Friction causes wear and tear of the parts of machinery in contact. Thus their lifetime reduces.

(iii) Frictional force result in the production of heat, which causes damage to the machinery.

5.6 Methods of Changing Friction

We can reduce friction

- (1) By polishing.
- (2) By lubrication.
- (3) By proper selection of material.
- (4) By streamlining the shape of the body.
- (5) By using ball bearing.

Also we can increase friction by throwing some sand on slippery ground. In the manufacturing of tyres, synthetic rubber is preferred because its coefficient of friction with the road is larger.

5.7 Angle of Friction

Angle of friction may be defined as the angle which the resultant of limiting friction and normal reaction makes with the normal reaction.

By definition angle θ is called the angle of friction

$$\tan \theta = \frac{F}{R}$$

$$\therefore \tan \theta = \mu \quad \left[\text{As we know } \frac{F}{R} = \mu \right]$$

$$\text{or } \theta = \tan^{-1}(\mu)$$

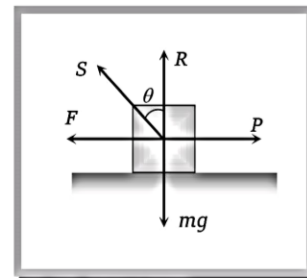

Hence coefficient of limiting friction is equal to tangent of the angle of friction.

5.8 Resultant Force Exerted by Surface on Block

In the above figure resultant force $S = \sqrt{F^2 + R^2}$

$$S = \sqrt{(\mu mg)^2 + (mg)^2}$$

$$S = mg\sqrt{\mu^2 + 1}$$

when there is no friction ($\mu = 0$) S will be minimum i.e., $S = mg$

Hence the range of S can be given by, $mg \leq S \leq mg\sqrt{\mu^2 + 1}$

5.9 Angle of Repose

Angle of repose is defined as the angle of the inclined plane with horizontal such that a body placed on it just begins to slide.

By definition α is called the angle of repose.

In limiting condition $F = mg \sin \alpha$

and $R = mg \cos \alpha$

So $\frac{F}{R} = \tan \alpha$

$\therefore \frac{F}{R} = \mu = \tan \theta = \tan \alpha$ [As we know $\frac{F}{R} = \mu = \tan \theta$]

Thus the coefficient of limiting friction is equal to the tangent of angle of repose.

As well as $\alpha = \theta$ i.e. angle of repose = angle of friction.

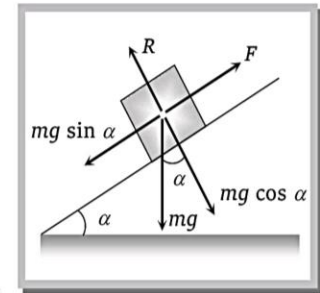

Sample problems based on angle of friction and angle of repose

Problem 7. A body of 5 kg weight kept on a rough inclined plane of angle 30° starts sliding with a constant velocity. Then the coefficient of friction is (assume $g = 10 \text{ m/s}^2$)

- (a) $1/\sqrt{3}$ (b) $2/\sqrt{3}$ (c) $\sqrt{3}$ (d) $2\sqrt{3}$

Solution : (a) Here the given angle is called the angle of repose

$$\text{So, } \mu = \tan 30^\circ = \frac{1}{\sqrt{3}}$$

Problem 8. The upper half of an inclined plane of inclination θ is perfectly smooth while the lower half is rough. A body starting from the rest at top comes back to rest at the bottom if the coefficient of friction for the lower half is given

- (a) $\mu = \sin \theta$ (b) $\mu = \cot \theta$ (c) $\mu = 2 \cos \theta$ (d) $\mu = 2 \tan \theta$

Solution : (d) For upper half by the equation of motion $v^2 = u^2 + 2as$

$$v^2 = 0^2 + 2(g \sin \theta)l/2 = gl \sin \theta \quad [\text{As } u = 0, s = l/2, a = g \sin \theta]$$

For lower half

$$0 = v^2 + 2g(\sin \theta - \mu \cos \theta) l/2 \quad [\text{As } v = 0, s = l/2, a = g(\sin \theta - \mu \cos \theta)]$$

$\Rightarrow 0 = gl \sin \theta + gl(\sin \theta - \mu \cos \theta)$ [As final velocity of upper half will be equal to the initial velocity of lower half]

$$\Rightarrow 2 \sin \theta = \mu \cos \theta \Rightarrow \mu = 2 \tan \theta$$

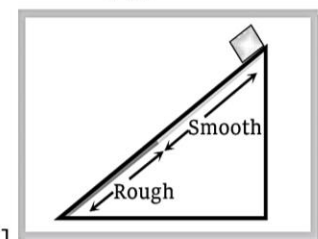

5.10 Calculation of Necessary Force in Different Conditions

If W = weight of the body, θ = angle of friction, $\mu = \tan \theta$ = coefficient of friction

then we can calculate necessary force for different condition in the following manner :

(1) Minimum pulling force P at an angle α from the horizontal

By resolving P in horizontal and vertical direction (as shown in fig)

For the condition of equilibrium

$$F = P \cos \alpha \quad \text{and} \quad R = W - P \sin \alpha$$

By substituting these value in $F = \mu R$

$$P \cos \alpha = \mu(W - P \sin \alpha)$$

$$\Rightarrow P \cos \alpha = \frac{\sin \theta}{\cos \theta} (W - P \sin \alpha) \quad [\text{As } \mu = \tan \theta]$$

$$\Rightarrow P = \frac{W \sin \theta}{\cos(\alpha - \theta)}$$

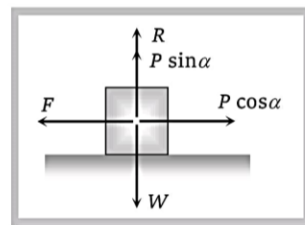
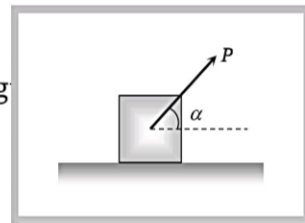

(2) Minimum pushing force P at an angle α from the horizontal

By Resolving P in horizontal and vertical direction (as shown in the

For the condition of equilibrium

$$F = P \cos \alpha \quad \text{and} \quad R = W + P \sin \alpha$$

By substituting these value in $F = \mu R$

$$\Rightarrow P \cos \alpha = \mu(W + P \sin \alpha)$$

$$\Rightarrow P \cos \alpha = \frac{\sin \theta}{\cos \theta} (W + P \sin \alpha) \quad [\text{As } \mu = \tan \theta]$$

$$\Rightarrow P = \frac{W \sin \theta}{\cos(\alpha + \theta)}$$

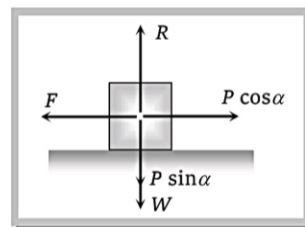
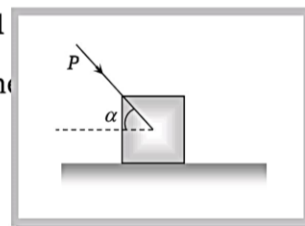

(3) Minimum pulling force P to move the body up an inclined plane

By Resolving P in the direction of the plane and perpendicular to the plane (as shown in the figure)

For the condition of equilibrium

$$R + P \sin \alpha = W \cos \lambda$$

$$\therefore R = W \cos \lambda - P \sin \alpha$$

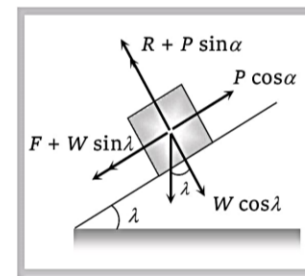
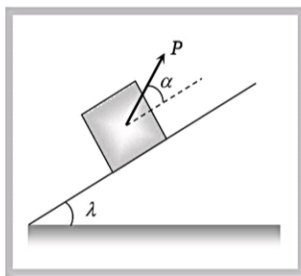

and $F + W \sin \lambda = P \cos \alpha$

$\therefore F = P \cos \alpha - W \sin \lambda$

By substituting these values in $F = \mu R$ and solving we get

$$P = \frac{W \sin(\theta + \lambda)}{\cos(\alpha - \theta)}$$

(4) Minimum force on body in downward direction along the surface of inclined plane to start its motion

By Resolving P in the direction of the plane and perpendicular to the plane (as shown in the figure)

For the condition of equilibrium

$$R + P \sin \alpha = W \cos \lambda$$

$\therefore R = W \cos \lambda - P \sin \alpha$

and $F = P \cos \alpha + W \sin \lambda$

By substituting these values in $F = \mu R$ and solving we get

$$P = \frac{W \sin(\theta - \lambda)}{\cos(\alpha - \theta)}$$

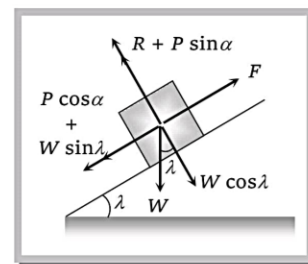
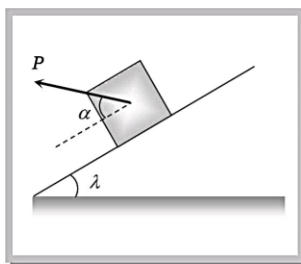

(5) Minimum force to avoid sliding a body down an inclined plane

By Resolving P in the direction of the plane and perpendicular to the plane (as shown in the figure)

For the condition of equilibrium

$$R + P \sin \alpha = W \cos \lambda$$

$\therefore R = W \cos \lambda - P \sin \alpha$

and $P \cos \alpha + F = W \sin \lambda$

$\therefore F = W \sin \lambda - P \cos \alpha$

By substituting these values in $F = \mu R$ and solving we get

$$P = W \left[\frac{\sin(\lambda - \theta)}{\cos(\theta + \alpha)} \right]$$

(6) Minimum force for motion and its direction

Let the force P be applied at an angle α with the horizontal.

By resolving P in horizontal and vertical direction (as shown in fi

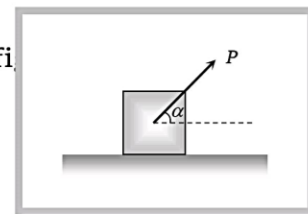

For vertical equilibrium

$$R + P \sin \alpha = mg$$

$$\therefore R = mg - P \sin \alpha \quad \dots(i)$$

and for horizontal motion

$$P \cos \alpha \geq F$$

$$\text{i.e. } P \cos \alpha \geq \mu R \quad \dots(ii)$$

Substituting value of R from (i) in (ii)

$$P \cos \alpha \geq \mu(mg - P \sin \alpha)$$

$$P \geq \frac{\mu mg}{\cos \alpha + \mu \sin \alpha} \quad \dots(iii)$$

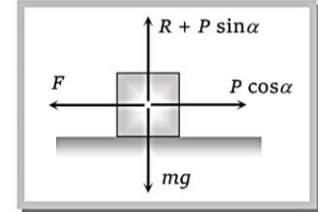

For the force P to be minimum $(\cos \alpha + \mu \sin \alpha)$ must be maximum i.e.

$$\frac{d}{d\alpha} [\cos \alpha + \mu \sin \alpha] = 0 \Rightarrow -\sin \alpha + \mu \cos \alpha = 0$$

$$\therefore \tan \alpha = \mu$$

$$\text{or } \alpha = \tan^{-1}(\mu) = \text{angle of friction}$$

i.e. For minimum value of P its angle from the horizontal should be equal to angle of friction

$$\text{As } \tan \alpha = \mu \text{ so from the figure } \sin \alpha = \frac{\mu}{\sqrt{1 + \mu^2}} \text{ and } \cos \alpha = \frac{1}{\sqrt{1 + \mu^2}}$$

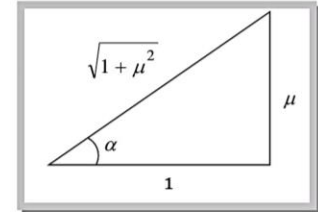

By substituting these value in equation (iii)

$$P \geq \frac{\mu mg}{\frac{1}{\sqrt{1 + \mu^2}} + \frac{\mu^2}{\sqrt{1 + \mu^2}}} \geq \frac{\mu mg}{\sqrt{1 + \mu^2}}$$

$$\therefore P_{\min} = \frac{\mu mg}{\sqrt{1 + \mu^2}}$$

Sample problems based on force against friction

Problem 9. What is the maximum value of the force F such that the block shown in the arrangement, does not move ($\mu = 1/2\sqrt{3}$)

- (a) 20 N
- (b) 10 N
- (c) 12 N
- (d) 15 N

Solution : (a) Frictional force $f = \mu R$

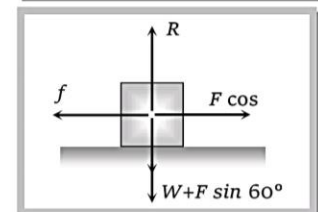
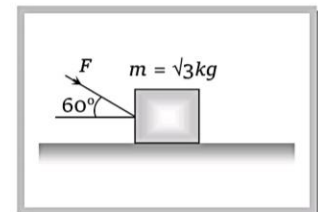

$$\Rightarrow F \cos 60 = \mu(W + F \sin 60)$$

$$\Rightarrow F \cos 60 = \frac{1}{2\sqrt{3}} (\sqrt{3}g + F \sin 60)$$

$$\Rightarrow F = 20 N.$$

Problem 10. A block of mass m rests on a rough horizontal surface as shown in the figure. Coefficient of friction between the block and the surface is μ . A force $F = mg$ acting at angle θ with the vertical side of the block pulls it. In which of the following cases the block can be pulled along the surface

(a) $\tan \theta \geq \mu$

(b) $\cot \theta \geq \mu$

(c) $\tan \theta / 2 \geq \mu$

(d) $\cot \theta / 2 \geq \mu$

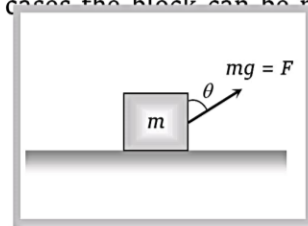

Solution : (d) For pulling of block $P \geq f$

$$\Rightarrow mg \sin \theta \geq \mu R \Rightarrow mg \sin \theta \geq \mu(mg - mg \cos \theta)$$

$$\Rightarrow \sin \theta \geq \mu(1 - \cos \theta)$$

$$\Rightarrow 2 \sin \frac{\theta}{2} \cos \frac{\theta}{2} \geq \mu \left(2 \sin^2 \frac{\theta}{2} \right) \Rightarrow \cot \left(\frac{\theta}{2} \right) \geq \mu$$

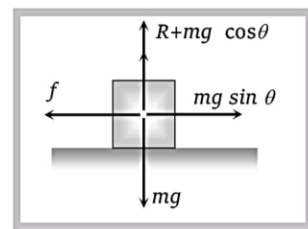

5.11 Acceleration of a Block Against Friction

(1) Acceleration of a block on horizontal surface

When body is moving under application of force P , then kinetic friction opposes its motion.

Let a is the net acceleration of the body

From the figure

$$ma = P - F_k$$

$$\therefore a = \frac{P - F_k}{m}$$

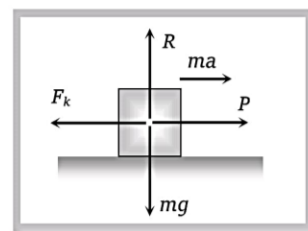

(2) Acceleration of a block down a rough inclined plane

When angle of inclined plane is more than angle of repose, the body placed on the inclined plane slides down with an acceleration a .

From the figure $ma = mg \sin \theta - F$

$$\Rightarrow ma = mg \sin \theta - \mu R$$

$$\Rightarrow ma = mg \sin \theta - \mu mg \cos \theta$$

$$\therefore \text{Acceleration } a = g[\sin \theta - \mu \cos \theta]$$

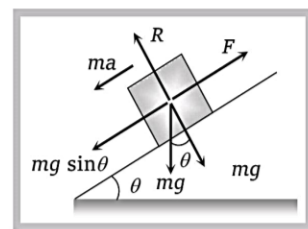

Note : \square For frictionless inclined plane $\mu = 0 \therefore a = g \sin \theta$.

(3) Retardation of a block up a rough inclined plane

When angle of inclined plane is less than angle of repose, then for the upward motion

$$ma = mg \sin \theta + F$$

$$ma = mg \sin \theta + \mu mg \cos \theta$$

$$\text{Retardation } a = g[\sin \theta + \mu \cos \theta]$$

Note : □ For frictionless inclined plane $\mu = 0 \therefore a = g \sin \theta$

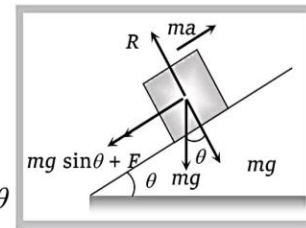

Sample problems based on acceleration against friction

Problem 11. A body of mass 10 kg is lying on a rough plane inclined at an angle of 30° to the horizontal and the coefficient of friction is 0.5. The minimum force required to pull the body up the plane is [JIPMER 2000]

- (a) 914 N (b) 91.4 N (c) 9.14 N (d) 0.914 N

Solution : (b) $F = mg(\sin \theta + \mu \cos \theta) = 10 \times 9.8(\sin 30 + 0.5 \cos 30) = 91.4 \text{ N}$

Problem 12. A block of mass 10 kg is placed on a rough horizontal surface having coefficient of friction $\mu = 0.5$. If a horizontal force of 100 N is acting on it, then acceleration of the block will be

- (a) 0.5 m/s^2 (b) 5 m/s^2 (c) 10 m/s^2 (d) 15 m/s^2

Solution : (b) $a = \frac{\text{Applied force} - \text{kinetic friction}}{\text{mass}} = \frac{100 - 0.5 \times 10 \times 10}{10} = 5 \text{ m/s}^2$.

Problem 13. A body of weight 64 N is pushed with just enough force to start it moving across a horizontal floor and the same force continues to act afterwards. If the coefficients of static and dynamic friction are 0.6 and 0.4 respectively, the acceleration of the body will be (Acceleration due to gravity = g) [EAMCET 2001]

- (a) $\frac{g}{6.4}$ (b) 0.64 g (c) $\frac{g}{32}$ (d) 0.2 g

Solution : (d) Limiting friction = $F_l = \mu_s R \Rightarrow 64 = 0.6 m g \Rightarrow m = \frac{64}{0.6g}$.

$$\text{Acceleration} = \frac{\text{Applied force} - \text{Kinetic friction}}{\text{Mass of the body}} = \frac{64 - \mu_k mg}{m} = \frac{64 - 0.4 \times \frac{64}{0.6}}{\frac{64}{0.6g}} = 0.2g$$

Problem 14. If a block moving up at $\theta = 30^\circ$ with a velocity 5 m/s, stops after 0.5 sec, then what is μ

- (a) 0.5 (b) 1.25 (c) 0.6 (d) None of these

Solution : (c) From $v = u - at \Rightarrow 0 = u - at \therefore t = \frac{u}{a}$

$$\text{for upward motion on an inclined plane } a = g(\sin \theta + \mu \cos \theta) \quad \therefore t = \frac{u}{g(\sin \theta + \mu \cos \theta)}$$

Substituting the value of $\theta = 30^\circ$, $t = 0.5 \text{ sec}$ and $u = 5 \text{ m/s}$, we get $\mu = 0.6$

5.12 Work Done Against Friction

(1) Work done over a rough inclined surface

If a body of mass m is moved up on a rough inclined plane through distance s , then

Work done = force \times distance

$$\begin{aligned} &= ma \times s \\ &= mg [\sin\theta + \mu \cos\theta]s \\ &= mg s [\sin\theta + \mu \cos\theta] \end{aligned}$$

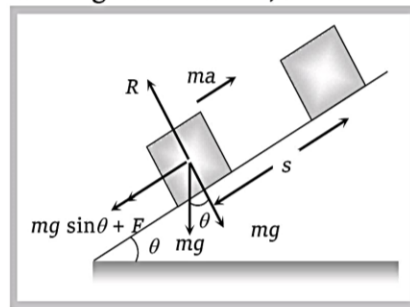

(2) Work done over a horizontal surface

In the above expression if we put $\theta = 0$ then

Work done = force \times distance

$$\begin{aligned} &= F \times s \\ &= \mu mg s \end{aligned}$$

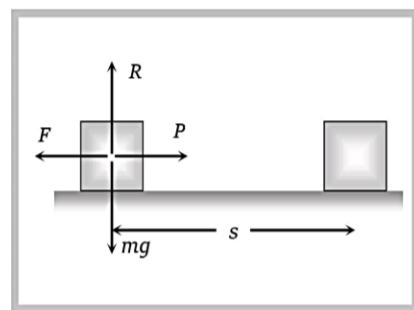

It is clear that work done depends upon

- (i) Weight of the body.
- (ii) Material and nature of surface in contact.
- (iii) Distance moved.

Sample problems based on work done against friction

Problem 15. A body of mass 5 kg rests on a rough horizontal surface of coefficient of friction 0.2 . The body is pulled through a distance of 10 m by a horizontal force of 25 N . The kinetic energy acquired by it is ($g = 10 \text{ ms}^{-2}$)

[EAMCET (Med.) 2000]

- (a) 330 J (b) 150 J (c) 100 J (d) 50 J

Solution : (b) Kinetic energy acquired by body = Total work done on the body - Work done against friction

$$= F \times S - \mu mgS = 25 \times 10 - 0.2 \times 5 \times 10 \times 10 = 250 - 100 = 150 \text{ J.}$$

Problem 16. 300 Joule of work is done in sliding a 2 kg . block up an inclined plane to a height of 10 meters . Taking value of acceleration due to gravity ' g ' to be 10 m/s^2 , work done against friction is

[MP PMT 2002]

- (a) 100 J (b) 200 J (c) 300 J (d) Zero

Solution : (a) Work done against gravity = $mgh = 2 \times 10 \times 10 = 200 \text{ J}$

Work done against friction = Total work done - Work done against gravity = $300 - 200 = 100 \text{ J.}$

Problem 17. A block of mass 1 kg slides down on a rough inclined plane of inclination 60° starting from its top. If the coefficient of kinetic friction is 0.5 and length of the plane is 1 m, then work done against friction is (Take $g = 9.8 \text{ m/s}^2$)

- (a) 9.82 J (b) 4.94 J (c) 2.45 J (d) 1.96 J

Solution : (c) $W = \mu mg \cos \theta \cdot S = 0.5 \times 1 \times 9.8 \times \frac{1}{2} = 2.45 \text{ J}$.

Problem 18. A block of mass 50 kg slides over a horizontal distance of 1 m. If the coefficient of friction between their surfaces is 0.2, then work done against friction is

- (a) 98 J (b) 72 J (c) 56 J (d) 34 J

Solution : (a) $W = \mu mgS = 0.2 \times 50 \times 9.8 \times 1 = 98 \text{ J}$.

5.13 Motion of Two Bodies One Resting on the Other

When a body A of mass m is resting on a body B of mass M then two conditions are possible

- (1) A force F is applied to the upper body, (2) A force F is applied to the lower body

We will discuss above two cases one by one in the following manner :

(1) **A force F is applied to the upper body, then following four situations are possible**

(i) **When there is no friction**

(a) The body A will move on body B with acceleration (F/m).

$$a_A = F/m$$

(b) The body B will remain at rest

$$a_B = 0$$

(c) If L is the length of B as shown in figure A will fall from B after

$$t = \sqrt{\frac{2L}{a}} = \sqrt{\frac{2mL}{F}} \quad \left[\text{As } s = \frac{1}{2}at^2 \text{ and } a = F/m \right]$$

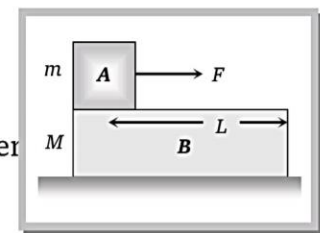

(ii) **If friction is present between A and B only and applied force is less than limiting friction ($F < F_l$)**

(F = Applied force on the upper body, F_l = limiting friction between A and B, F_k = Kinetic friction between A and B)

(a) The body A will not slide on body B till $F < F_l$ i.e. $F < \mu_s mg$

(b) Combined system ($m + M$) will move together with common acceleration

$$a_A = a_B = \frac{F}{M + m}$$

(iii) **If friction is present between A and B only and applied force is greater than limiting friction ($F > F_l$)**

In this condition the two bodies will move in the same direction (i.e. of applied force) but with different acceleration. Here force of kinetic friction $\mu_k mg$ will oppose the motion of A while will cause the motion of B.

$F - F_k = m a_A$ <p>i.e.</p> $a_A = \frac{F - F_k}{m}$ $a_A = \frac{(F - \mu_k mg)}{m}$	<p>Free body diagram of A</p>	$F_k = M a_B$ <p>i.e.</p> $a_B = \frac{F_k}{M}$ $\therefore a_B = \frac{\mu_k mg}{M}$	<p>Free body diagram of B</p>
--	-------------------------------	---	-------------------------------

Note : □ As both the bodies are moving in the same direction.

Acceleration of body A relative to B will be $a = a_A - a_B = \frac{MF - \mu_k mg (m + M)}{mM}$

So, A will fall from B after time $t = \sqrt{\frac{2L}{a}} = \sqrt{\frac{2mML}{MF - \mu_k mg (m + M)}}$

(iv) If there is friction between B and floor

(where $F'_i = \mu'(M + m)g =$ limiting friction between B and floor, $F_k =$ kinetic friction between A and B)

B will move only if $F_k > F'_i$ and then $F_k - F'_i = M a_B$

However if B does not move then static friction will work (not limiting friction) between body B and the floor i.e. friction force = applied force (= F_k) not F'_i .

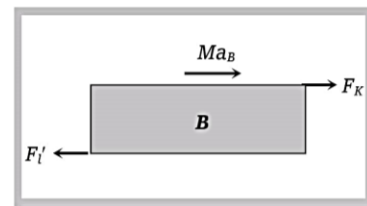

(2) A force F is applied to the lower body, then following four situations are possible

(i) When there is no friction

(a) B will move with acceleration (F/M) while A will remain at rest (relative to ground) as there is no pulling force on A.

$$a_B = \left(\frac{F}{M}\right) \text{ and } a_A = 0$$

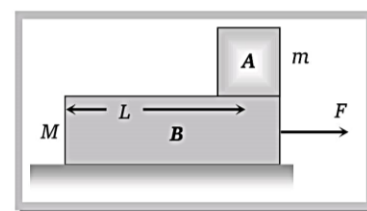

(b) As relative to B, A will move backwards with acceleration (F/M) and so will fall from it in time t .

$$\therefore t = \sqrt{\frac{2L}{a}} = \sqrt{\frac{2ML}{F}}$$

(ii) If friction is present between A and B only and $F' < F_i$

(where $F' =$ Pseudo force on body A and $F_i =$ limiting friction between body A and B)

(a) Both the body will move together with common acceleration $a = \frac{F}{M + m}$

(b) Pseudo force on the body A, $F' = ma = \frac{mF}{m + M}$ and $F_i = \mu_s mg$

$$(c) F' < F_l \Rightarrow \frac{mF}{m+M} < \mu_s mg \Rightarrow F < \mu_s(m+M)g$$

So both bodies will move together with acceleration $a_A = a_B = \frac{F}{m+M}$ if $F < \mu_s[m+M]g$

(iii) **If friction is present between A and B only and $F > F_l'$**

(where $F_l' = \mu_s(m+M)g =$ limiting friction between body B and surface)

Both the body will move with different acceleration. Here force of kinetic friction $\mu_k mg$ will oppose the motion of B while will cause the motion of A.

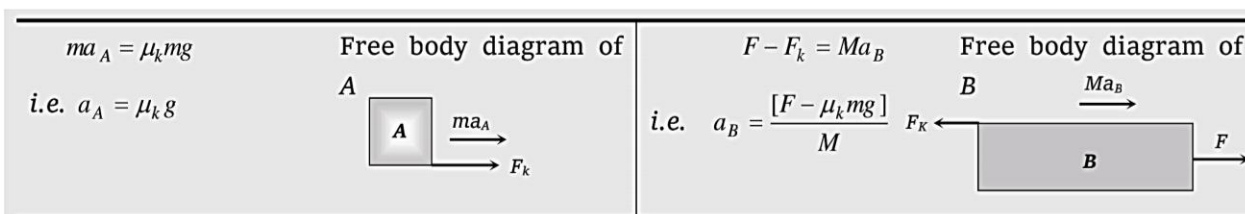

Note : □ As both the bodies are moving in the same direction

Acceleration of body A relative to B will be

$$a = a_A - a_B = -\left[\frac{F - \mu_k g(m+M)}{M}\right]$$

Negative sign implies that relative to B, A will move backwards and will fall it after time

$$t = \sqrt{\frac{2L}{a}} = \sqrt{\frac{2ML}{F - \mu_k g(m+M)}}$$

(iv) **If there is friction between B and floor** : The system will move only if $F > F_l'$ then replacing F by $F - F_l'$. The entire case (iii) will be valid.

However if $F < F_l'$ the system will not move and friction between B and floor will be F while between A and B is zero.

Sample problems based on body resting on another

Problem 19. A 4 kg block A is placed on the top of a 8 kg block B which rests on a smooth table. A just slips on B when a force of 12 N is applied on A. Then the maximum horizontal force on B to make both A and B move together, is

- (a) 12 N (b) 24 N (c) 36 N (d) 48 N

Solution : (c) Maximum friction i.e. limiting friction between A and B, $F_l = 12$ N.

If F is the maximum value of force applied on lower body such that both body move together

It means Pseudo force on upper body is just equal to limiting friction

$$F' = F_f \Rightarrow m \left(\frac{F}{m+M} \right) = \left(\frac{4}{4+8} \right) F = 12 \therefore F = 36 N.$$

Problem 20. A body A of mass 1 kg rests on a smooth surface. Another body B of mass 0.2 kg is placed over A as shown. The coefficient of static friction between A and B is 0.15. B will begin to slide on A if A is pulled with a force greater than

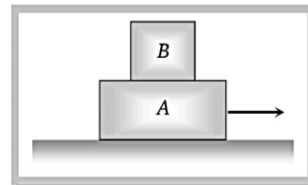

- (a) 1.764 N
- (b) 0.1764 N
- (c) 0.3 N
- (d) It will not slide for any F

Solution : (a) B will begin to slide on A if Pseudo force is more than limiting friction

$$F' > F_f \Rightarrow m \left(\frac{F}{m+M} \right) > \mu_s R \Rightarrow m \left(\frac{F}{m+M} \right) > 0.15 mg \therefore F > 1.764 N$$

Problem 21. A block A of mass 2 kg rests on another block B of mass 8 kg which rests on a horizontal floor. The coefficient of friction between A and B is 0.2, while that between B and floor is 0.5. When a horizontal force of 25 N is applied on the block B, the force of friction between A and B is [IIT-JEE 1993]

- (a) Zero
- (b) 3.9 N
- (c) 5.0 N
- (d) 49 N

Solution : (a) Limiting friction between the block B and the surface

$$F_{BS} = \mu_{BS} \cdot R = 0.5(m+M)g = 0.5(2+8)10 = 50 N$$

but the applied force is 25 N so the lower block will not move i.e. there is no pseudo force on upper block A. Hence there will be no force of friction between A and B.

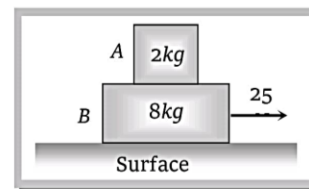

5.14 Motion of an Insect in the Rough Bowl

The insect crawl up the bowl up to a certain height h only till the component of its weight along the bowl is balanced by limiting frictional force.

Let m = mass of the insect, r = radius of the bowl, μ = coefficient of friction for limiting condition at point A

$$R = mg \cos \theta \quad \dots\dots(i) \quad \text{and} \quad F_f = mg \sin \theta \quad \dots\dots(ii)$$

Dividing (ii) by (i)

$$\tan \theta = \frac{F_f}{R} = \mu \quad [\text{As } F_f = \mu R]$$

$$\therefore \frac{\sqrt{r^2 - y^2}}{y} = \mu \quad \text{or} \quad y = \frac{r}{\sqrt{1 + \mu^2}}$$

$$\text{So} \quad h = r - y = r \left[1 - \frac{1}{\sqrt{1 + \mu^2}} \right], \therefore h = r \left[1 - \frac{1}{\sqrt{1 + \mu^2}} \right]$$

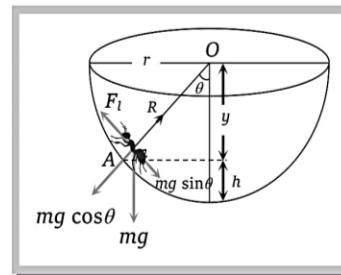

Problem 22. An insect crawls up a hemispherical surface very slowly (see the figure). The coefficient of friction between the insect and the surface is $1/3$. If the line joining the centre of the hemispherical surface to the insect makes an angle α with the vertical, the maximum possible value of α is given by [IIT-JEE (Screening) 2001]

- (a) $\cot \alpha = 3$
- (b) $\tan \alpha = 3$
- (c) $\sec \alpha = 3$
- (d) $\operatorname{cosec} \alpha = 3$

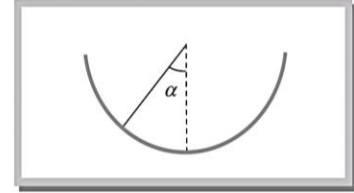

Solution : (a) From the above expression, for the equilibrium $R = mg \cos \alpha$ and $F = mg \sin \alpha$.

Substituting these value in $F = \mu R$ we get $\tan \alpha = \mu$ or $\cot \alpha = \frac{1}{\mu} = 3$.

5.15 Minimum Mass Hung From the String to Just Start the Motion

(1) **When a mass m_1 placed on a rough horizontal plane :** Another mass m_2 hung from the string connected by pulley, the tension (T) produced in string will try to start the motion of mass m_1 .

At limiting condition

$$T = F_f$$

$$\Rightarrow m_2 g = \mu R$$

$$\Rightarrow m_2 g = \mu m_1 g$$

$\therefore m_2 = \mu m_1$ this is the minimum value of m_2 to start the motion

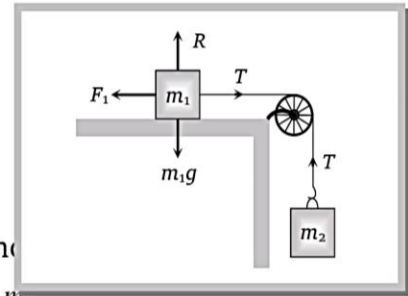

Note : \square In the above condition Coefficient of friction $\mu = \frac{m_2}{m_1}$

(2) **When a mass m_1 placed on a rough inclined plane :** Another mass m_2 hung from the string connected by pulley, the tension (T) produced in string will try to start the motion of mass m_1 .

At limiting condition

$$\text{For } m_2 \quad T = m_2 g \quad \dots\dots (i)$$

$$\text{For } m_1 \quad T = m_1 g \sin \theta + F \Rightarrow T = m_1 g \sin \theta + \mu R$$

$$\Rightarrow T = m_1 g \sin \theta + \mu m_1 g \cos \theta \quad \dots\dots (ii)$$

$$\text{From equation (i) and (ii) } m_2 = m_1 [\sin \theta + \mu \cos \theta]$$

this is the minimum value of m_2 to start the motion

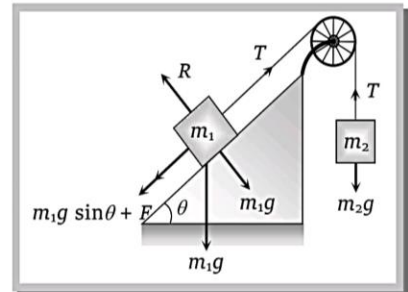

Note : \square In the above condition Coefficient of friction

$$\mu = \left[\frac{m_2}{m_1 \cos \theta} - \tan \theta \right]$$

Sample problems based on hung mass

Problem 23. Two blocks of mass M_1 and M_2 are connected with a string passing over a pulley as shown in the figure. The block M_1 lies on a horizontal surface. The coefficient of friction between the block M_1 and horizontal surface is μ . The system accelerates. What additional mass m should be placed on the block M_1 so that the system does not accelerate

- (a) $\frac{M_2 - M_1}{\mu}$
 (b) $\frac{M_2}{\mu} - M_1$
 (c) $M_2 - \frac{M_1}{\mu}$
 (d) $(M_2 - M_1)\mu$

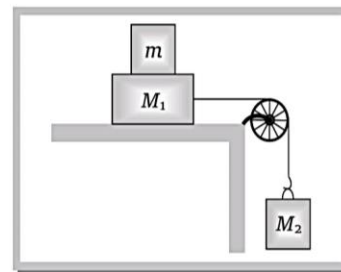

Solution : (b) By comparing the given condition with general expression

$$\mu = \frac{M_2}{m + M_1} \Rightarrow m + M_1 = \frac{M_2}{\mu} \Rightarrow m = \frac{M_2}{\mu} - M_1$$

Problem 24. The coefficient of kinetic friction is 0.03 in the diagram where mass $m_2 = 20 \text{ kg}$ and $m_1 = 4 \text{ kg}$. The acceleration of the block shall be ($g = 10 \text{ ms}^{-2}$)

- (a) 1.8 ms^{-2}
 (b) 0.8 ms^{-2}
 (c) 1.4 ms^{-2}
 (d) 0.4 ms^{-2}

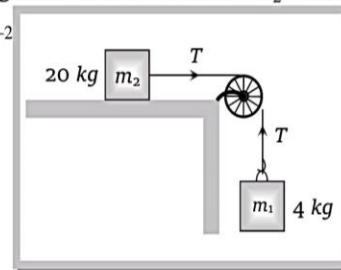

Solution : (c) Let the acceleration of the system is a

From the F.B.D. of m_2

$$T - F = m_2 a \Rightarrow T - \mu m_2 g = m_2 a$$

$$\Rightarrow T - 0.03 \times 20 \times 10 = 20a \Rightarrow T - 6 = 20a \quad \dots(i)$$

From the FBD of m_1

$$m_1 g - T = m_1 a$$

$$\Rightarrow 4 \times 10 - T = 4a \Rightarrow 40 - T = 4a \quad \dots(ii)$$

Solving (i) and (ii) $a = 1.4 \text{ m/s}^2$.

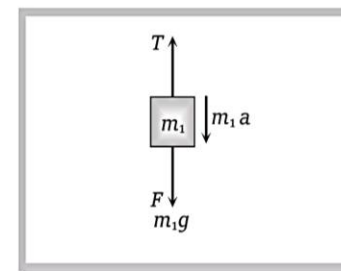
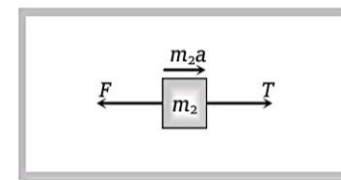

5.16 Maximum Length of Hung Chain

A uniform chain of length l is placed on the table in such a manner that its l' part is hanging over the edge of table with out sliding. Since the chain have uniform linear density therefore the ratio of mass or ratio of length for any part of the chain will be equal.

We know $\mu = \frac{m_2}{m_1} = \frac{\text{mass hanging from the table}}{\text{mass lying on the table}}$ [From article 5.15]

\therefore For this expression we can rewrite above expression in the following manner

$\mu = \frac{\text{length hanging from the table}}{\text{length lying on the table}}$ [As chain have uniform linear densit

$$\therefore \mu = \frac{l'}{l-l'}$$

by solving $l' = \frac{\mu l}{(\mu + 1)}$

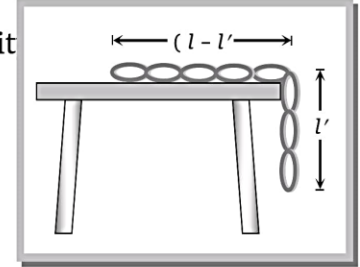

Problem 25. A heavy uniform chain lies on a horizontal table top. If the coefficient of friction between the chain and the table surface is 0.25, then the maximum fraction of the length of the chain that can hang over one edge of the table is

- (a) 20% (b) 25% (c) 35% (d) 15%

Solution : (a) From the expression $l' = \left(\frac{\mu}{\mu + 1}\right)l = \left(\frac{0.25}{0.25 + 1}\right)l$ [As $\mu = 0.25$]

$$\Rightarrow l' = \frac{0.25}{1.25}l = \frac{l}{5} = 20\% \text{ of the length of the chain.}$$

5.17 Coefficient of Friction Between Body and Wedge

A body slides on a smooth wedge of angle θ and its time of descent is t .

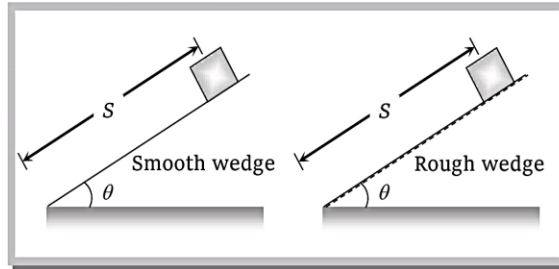

If the same wedge made rough then time taken by it to come down becomes n times more (i.e. nt)

The length of path in both the cases are same.

For smooth wedge

$$S = ut + \frac{1}{2}at^2$$

$$S = \frac{1}{2}(g \sin \theta)t^2 \quad \dots(i)$$

[As $u = 0$ and $a = g \sin \theta$]

For rough wedge

$$S = ut + \frac{1}{2}at^2$$

$$S = \frac{1}{2}g(\sin \theta - \mu \cos \theta)(nt)^2 \quad \dots(ii)$$

[As $u = 0$ and $a = g(\sin \theta - \mu \cos \theta)$]

From equation (i) and (ii) $\frac{1}{2}(g \sin \theta)t^2 = \frac{1}{2}g(\sin \theta - \mu \cos \theta)(nt)^2$

$$\Rightarrow \sin \theta = (\sin \theta - \mu \cos \theta)n^2$$

$$\Rightarrow \mu = \tan \theta \left[1 - \frac{1}{n^2} \right]$$

Problem 26. A body takes just twice the time as long to slide down a plane inclined at 30° to the horizontal as if the plane were frictionless. The coefficient of friction between the body and the plane is [JIPMER 1999]

- (a) $\frac{\sqrt{3}}{4}$ (b) $\sqrt{3}$ (c) $\frac{4}{3}$ (d) $\frac{3}{4}$

Solution : (a) $\mu = \tan \theta \left(1 - \frac{1}{n^2} \right) = \tan 30 \left(1 - \frac{1}{2^2} \right) = \frac{\sqrt{3}}{4}$.

5.18 Stopping of Block Due to Friction

(1) On horizontal road

(i) **Distance travelled before coming to rest :** A block of mass m is moving initially with velocity u on a rough surface and due to friction it comes to rest after

Retarding force $F = ma = \mu R$

$$\Rightarrow ma = \mu mg$$

$$\therefore a = \mu g$$

From $v^2 = u^2 - 2aS \Rightarrow 0 = u^2 - 2\mu g S$ [As $v = 0, a = \mu g$]

$$\therefore S = \frac{u^2}{2\mu g}$$

or $S = \frac{P^2}{2\mu m^2 g}$ [As momentum $P = mu$]

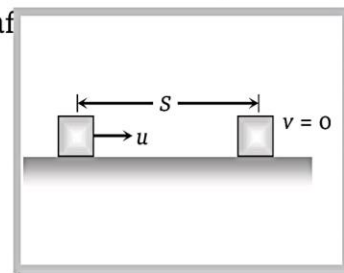

(ii) Time taken to come to rest

From equation $v = u - at \Rightarrow 0 = u - \mu g t$ [As $v = 0, a = \mu g$]

$$\therefore t = \frac{u}{\mu g}$$

(iii) Force of friction acting on the body

We know, $F = ma$

So, $F = m \frac{(v - u)}{t}$

$$F = \frac{mu}{t}$$
 [As $v = 0$]

$$F = \mu mg$$
 [As $t = \frac{u}{\mu g}$]

(2) **On inclined road** : When block starts with velocity u its kinetic energy will be converted into potential energy and some part of it goes against friction and after travelling distance S it comes to rest i.e. $v = 0$.

And we know that retardation $a = g[\sin \theta + \mu \cos \theta]$

By substituting the value of v and a in the following equation

$$v^2 = u^2 - 2aS$$

$$\Rightarrow 0 = u^2 - 2g[\sin \theta + \mu \cos \theta]S$$

$$\therefore S = \frac{u^2}{2g(\sin \theta + \mu \cos \theta)}$$

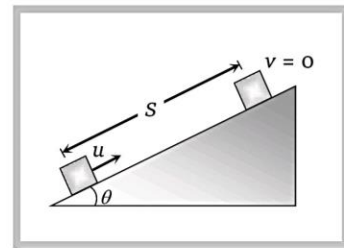

Sample problems based on motion of body on rough surface

Problem 27. A marble block of mass 2 kg lying on ice when given a velocity of 6 m/s is stopped by friction in 10s . Then the coefficient of friction is

- (a) 0.01 (b) 0.02 (c) 0.03 (d) 0.06

Solution : (d) $v = u - at = u - \mu g t = 0$

$$\therefore \mu = \frac{u}{gt} = \frac{6}{10 \times 10} = 0.06 .$$

Problem 28. A 2 kg mass starts from rest on an inclined smooth surface with inclination 30° and length 2 m . How much will it travel before coming to rest on a surface with coefficient of friction 0.25 [UPSEAT 2003]

- (a) 4 m (b) 6 m (c) 8 m (d) 2 m

Solution : (a) $v^2 = u^2 + 2aS = 0 + 2 \times g \sin 30 \times 2$

$$v = \sqrt{20}$$

Let it travel distance 'S' before coming to rest

$$S = \frac{v^2}{2\mu g} = \frac{20}{2 \times 0.25 \times 10} = 4\text{m}.$$

5.19 Stopping of Two Blocks Due to Friction

When two masses compressed towards each other and suddenly released then energy acquired by each block will be dissipated against friction and finally block comes to rest

i.e., $F \times S = E$ [Where $F = \text{Friction}$, $S = \text{Distance covered by block}$, $E = \text{Initial kinetic energy of the block}$]

$$\Rightarrow F \times S = \frac{P^2}{2m} \quad [\text{Where } P = \text{momentum of block}]$$

$$\Rightarrow \mu mg \times S = \frac{P^2}{2m} \quad [\text{As } F = \mu mg]$$

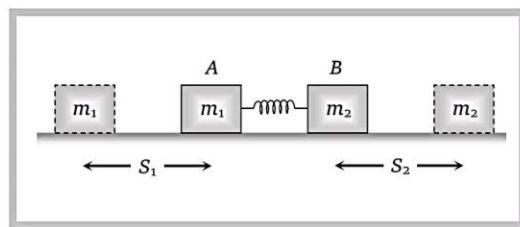

$$\Rightarrow S = \frac{P^2}{2\mu m^2 g}$$

In a given condition P and μ are same for both the blocks.

$$\text{So } S \propto \frac{1}{m^2} \therefore \frac{S_1}{S_2} = \left[\frac{m_2}{m_1} \right]^2$$

5.20 Velocity at the Bottom of Rough Wedge

A body of mass m which is placed at the top of the wedge (of height h) starts moving downward on a rough inclined plane.

Loss of energy due to friction = FL (Work against friction)

PE at point A = mgh

KE at point B = $\frac{1}{2}mv^2$

By the law of conservation of energy

$$\text{i.e. } \frac{1}{2}mv^2 = mgh - FL$$

$$v = \sqrt{\frac{2}{m}(mgh - FL)}$$

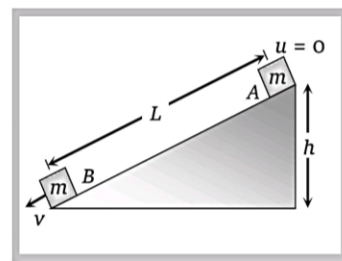

5.21 Sticking of a Block With Accelerated Cart

When a cart moves with some acceleration toward right then a pseudo force (ma) acts on block toward left.

This force (ma) is action force by a block on cart.

Now block will remain static w.r.t. block. If friction force $\mu R \geq$

$$\Rightarrow \mu ma \geq mg \quad [\text{As } R = ma]$$

$$\Rightarrow a \geq \frac{g}{\mu}$$

$$\therefore a_{\min} = \frac{g}{\mu}$$

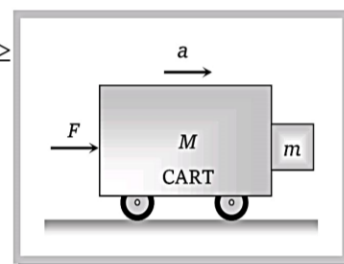
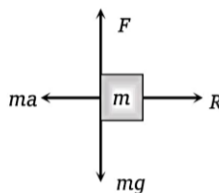

This is the minimum acceleration of the cart so that block does not fall.

and the minimum force to hold the block together

$$F_{\min} = (M + m)a_{\min}$$

$$F_{\min} = (M + m)\frac{g}{\mu}$$

5.22 Sticking of a Person With the Wall of Rotor

A person with a mass m stands in contact against the wall of a cylindrical drum (rotor). The coefficient of friction between the wall and the clothing is μ .

If Rotor starts rotating about its axis, then person thrown away from the centre due to centrifugal force at a particular speed w , the person stuck to the wall even the floor is removed, because friction force balances its weight in this condition.

From the figure.

Friction force (F) = weight of person (mg)

$$\Rightarrow \mu R = mg$$

$$\Rightarrow \mu F_c = mg \quad [\text{Here, } F_c = \text{centrifugal force}]$$

$$\Rightarrow \mu m \omega_{\min}^2 r = mg$$

$$\therefore \omega_{\min} = \sqrt{\frac{g}{\mu r}}$$

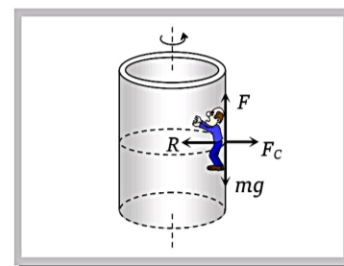

Sample problems (Miscellaneous)

Problem 29. A motorcycle is travelling on a curved track of radius 500m if the coefficient of friction between road and tyres is 0.5. The speed avoiding skidding will be

- (a) 50 m/s (b) 75 m/s (c) 25 m/s (d) 35 m/s

Solution : (a) $v = \sqrt{\mu rg} = \sqrt{0.5 \times 500 \times 10} = 50 \text{ m/s}$.

Problem 30. A horizontal force of 10 N is necessary to just hold a block stationary against a wall. The coefficient of friction between the block and the wall is 0.2. The weight of the block is

- (a) 2 N
(b) 20 N
(c) 50 N
(d) 100 N

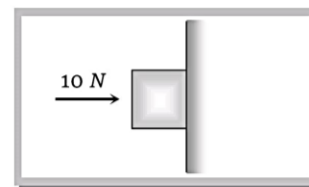

Solution : (a) For equilibrium

$$\text{Weight (W)} = \text{Force of friction (F)}$$

$$W = \mu R = 0.2 \times 10 = 2 \text{ N}$$

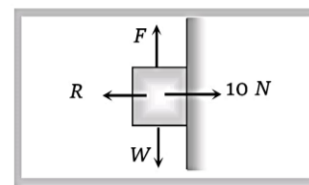

Problem 31. A body of mass 2 kg is kept by pressing to a vertical wall by a force of 100 N. The friction between wall and body is 0.3. Then the frictional force is equal to

- (a) 6 N (b) 20 N (c) 600 N (d) 700 N

Solution : (b) For the given condition Static friction = Applied force = Weight of body = $2 \times 10 = 20 \text{ N}$.

Problem 32. A fireman of mass 60 kg slides down a pole. He is pressing the pole with a force of 600 N . The coefficient of friction between the hands and the pole is 0.5 , with what acceleration will the fireman slide down ($g = 10 \text{ m/s}^2$)

- (a) 1 m/s^2 (b) 2.5 m/s^2 (c) 10 m/s^2 (d) 5 m/s^2

Solution : (d) Friction = $\mu R = 0.5 \times 600 = 300 \text{ N}$, Weight = 600 N

$$ma = W - F \Rightarrow a = \frac{W - F}{m} = \frac{600 - 300}{60}$$

$$\therefore a = 5 \text{ m/s}^2$$

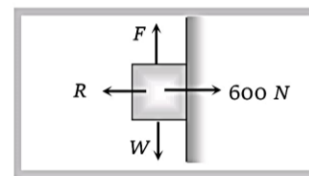

Problem 33. The system shown in the figure is in equilibrium. The maximum value of W , so that the maximum value of static frictional force on 100 kg body is

- (a) 100 N
(b) 250 N
(c) 450 N
(d) 1000 N

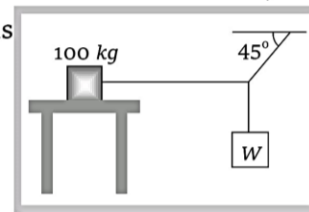

Solution : (c) For vertical equilibrium $T_1 \sin 45^\circ = W \quad \therefore T_1 = \frac{W}{\sin 45^\circ}$

For horizontal equilibrium $T_2 = T_1 \cos 45^\circ = \frac{W}{\sin 45^\circ} \cos 45^\circ = W$

and for the critical condition $T_2 = F$

$$\therefore W = T_2 = F = 450 \text{ N}$$

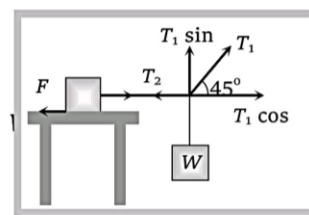



Practice Problems

► Basic level

- When a body is moving on a surface, the force of friction is called [MP PET 2002]
 (a) Static friction (b) Dynamic friction (c) Limiting friction (d) Rolling friction
- Which one of the following is not used to reduce friction [Kerala (Engg.) 2001]
 (a) Oil (b) Ball bearings (c) Sand (d) Graphite
- A block of mass 10 kg is placed on an inclined plane. When the angle of inclination is 30° , the block just begins to slide down the plane. The force of static friction is
 (a) 10 kg wt (b) 89 kg wt (c) 49 kg wt (d) 5 kg wt
- A vehicle of mass m is moving on a rough horizontal road with momentum P . If the coefficient of friction between the tyres and the road be μ , then the stopping distance is [CBSE PMT 2001]
 (a) $\frac{P}{2\mu m g}$ (b) $\frac{P^2}{2\mu m g}$ (c) $\frac{P}{2\mu m^2 g}$ (d) $\frac{P^2}{2\mu m^2 g}$
- A box is lying on an inclined plane what is the coefficient of static friction if the box starts sliding when an angle of inclination is 60° [KCET (Engg./Med.) 2000]
 (a) 1.173 (b) 1.732 (c) 2.732 (d) 1.677
- A brick of mass 2 kg begins to slide down on a plane inclined at an angle of 45° with the horizontal. The force of friction will be [CPMT 2000]
 (a) $19.6 \sin 45^\circ$ (b) $19.6 \cos 45^\circ$ (c) $9.8 \sin 45^\circ$ (d) $9.8 \cos 45^\circ$
- To avoid slipping while walking on ice, one should take smaller steps because of the [BHU 1999]
 (a) Friction of ice is large (b) Larger normal reaction

- (c) Friction of ice is small (d) Smaller normal reaction
8. Two bodies having the same mass, 2 kg each have different surface areas 50 m^2 and 100 m^2 in contact with a horizontal plane. If the coefficient of friction is 0.2 , the forces of friction that come into play when they are in motion will be in the ratio
- [EAMCET (Med.) 1999]
- (a) 1 : 1 (b) 1 : 2 (c) 2 : 1 (d) 1 : 4
9. Starting from rest, a body slides down a 45° inclined plane in twice the time it takes to slide down the same distance in the absence of friction. The coefficient of friction between the body and the inclined plane is
- [CBSE PMT 1990]
- (a) 0.33 (b) 0.25 (c) 0.75 (d) 0.80
10. Brakes of very small contact area are not used although friction is independent of area, because friction
- (a) Resists motion (b) Causes wear and tear
(c) Depends upon the nature of materials (d) Operating in this case is sliding friction
11. The angle between frictional force and the instantaneous velocity of the body moving over a rough surface is
- (a) Zero (b) $\pi/2$
(c) π (d) Equal to the angle of friction
12. What happens to the coefficient of friction, when the normal reaction is halved
- (a) Halved (b) Doubled
(c) No change (d) Depends on the nature of the surface
13. What can be inferred regarding the limiting frictional force in the following four figures

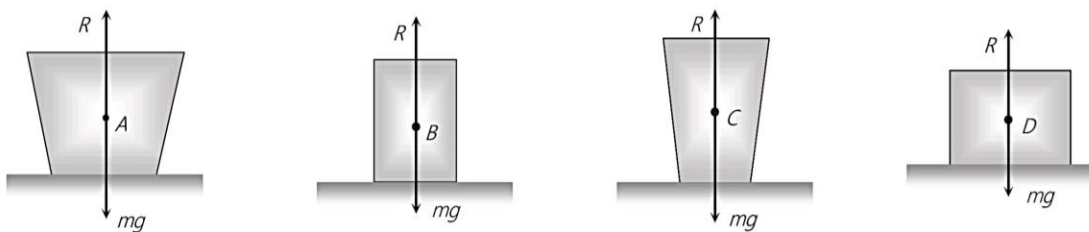

- (a) $F_A = F_B = F_C = F_D$ (b) $F_A > F_B > F_C > F_D$ (c) $F_A < F_B < F_C < F_D$ (d) $F_A = F_B < F_C < F_D$
14. A force of 98 Newton is required to drag a body of mass 100 kg on ice. The coefficient of friction will be
- (a) 0.98 (b) 0.89 (c) 0.49 (d) 0.1

15. A 60 kg body is pushed with just enough force to start it moving across a floor and the same force continues to act afterwards. The coefficients of static and sliding friction are 0.5 and 0.4 respectively. The acceleration of the body is
- (a) $6 m / \text{sec}^2$ (b) $4.9 m / \text{sec}^2$ (c) $3.92 m / \text{sec}^2$ (d) $1 m / \text{sec}^2$
16. A particle is projected along a line of greatest slope up a rough plane inclined at an angle of 45° with the horizontal. If the coefficient of friction is $\frac{1}{2}$, then the retardation is
- (a) $\frac{g}{\sqrt{2}}$ (b) $\frac{g}{2\sqrt{2}}$ (c) $\frac{g}{\sqrt{2}} \left[1 + \frac{1}{2} \right]$ (d) $\frac{g}{\sqrt{2}} \left[1 - \frac{1}{2} \right]$
17. A block moves down a smooth inclined plane of inclination θ . Its velocity on reaching the bottom is v . If it slides down a rough inclined plane of same inclination its velocity on reaching the bottom is v/n , where n is a number greater than 0. The coefficient of friction μ is given by
- (a) $\mu = \tan \theta \left[1 - \frac{1}{n^2} \right]$ (b) $\mu = \cot \theta \left[1 - \frac{1}{n^2} \right]$ (c) $\mu = \tan \theta \left[1 - \frac{1}{n^2} \right]^{\frac{1}{2}}$ (d) $\mu = \cot \theta \left[1 - \frac{1}{n^2} \right]^{\frac{1}{2}}$
18. Consider a car moving along a straight horizontal road with a speed of 72 km/hr. If the coefficient of static friction between the tyres and the road is 0.5, the shortest distance in which the car can be stopped is ($g = 10 m / s^2$)
- (a) 30 m (b) 40 m (c) 72 m (d) 20 m
19. All the surfaces shown in the figure are rough. The direction of friction on B due to A is

- (a) Zero
 (b) To the left
 (c) Upwards
 (d) Downwards

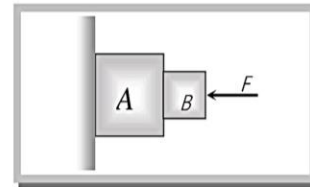

20. A body of mass M just starts sliding down an inclined plane (rough) with inclination θ , such that $\tan \theta = 1/3$. The force acting on the body down the plane in this position is
- (a) Mg (b) $\frac{Mg}{3}$ (c) $\frac{2}{3} Mg$ (d) $\frac{Mg}{\sqrt{10}}$

►► **Advance level**

21. Consider the following statements

Assertion (A) : It is difficult to move a cycle along the road with its brakes on.

Reason (R) : Sliding friction is greater than rolling friction.

Of these statements

[AIIMS 2002]

- (a) Both A and R are true and the R is a correct explanation of the A
- (b) Both A and R are true but the R is not a correct explanation of the A
- (c) A is true but the R is false
- (d) Both A and R are false
- (e) A is false but the R is true

22. A body is sliding down an inclined plane having coefficient of friction 0.5. If the normal reaction is twice that of the resultant downward force along the incline, the angle between the inclined plane and the horizontal is [EAMCET (Engg.) 2000]

- (a) 15°
- (b) 30°
- (c) 45°
- (d) 60°

23. A block of mass 2 kg rests on a rough inclined plane making an angle of 30° with the horizontal. The coefficient of static friction between the block and the plane is 0.7. The frictional force on the block is [IIT-JEE 1980]

- (a) 9.8 N
- (b) $0.7 \times 9.8 \times \sqrt{3} \text{ N}$
- (c) $9.8 \times \sqrt{3} \text{ N}$
- (d) $0.7 \times 9.8 \text{ N}$

24. A body of weight W is lying at rest on a rough horizontal surface. If the angle of friction is θ , then the minimum force required to move the body along the surface will be

- (a) $W \tan \theta$
- (b) $W \cos \theta$
- (c) $W \sin \theta$
- (d) $W \cos \theta$

25. A block of mass M is placed on a rough horizontal surface as shown in the figure. A force $F = Mg$ acts on the block. It is inclined to the vertical at an angle θ . The coefficient of friction is μ . The block can be pushed along the surface only when

- (a) $\tan \theta \geq \mu$
- (b) $\cot \theta \geq \mu$
- (c) $\tan \theta / 2 \geq \mu$
- (d) $\cot \theta / 2 \geq \mu$

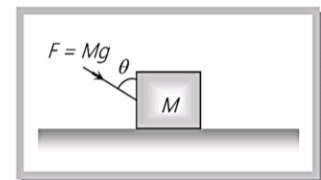

26. A plane is inclined at an angle θ with the horizontal. A body of mass m rests on it. If the coefficient of friction is μ , then the minimum force that has to be applied parallel to the inclined plane to make the body just move up the inclined plane is

- (a) $mg \sin \theta$
- (b) $\mu mg \cos \theta$
- (c) $\mu mg \cos \theta - mg \sin \theta$
- (d) $\mu mg \cos \theta + mg \sin \theta$

27. A block of mass m is placed on another block of mass M which itself is lying on a horizontal surface. The coefficient of friction between the two blocks is μ_1 and that between the block of mass M and horizontal surface is μ_2 . What maximum horizontal force can be applied to the lower block so that the two blocks move without separation

- (a) $(M + m)(\mu_2 - \mu_1)g$
- (b) $(M - m)(\mu_2 - \mu_1)g$
- (c) $(M - m)(\mu_2 + \mu_1)g$

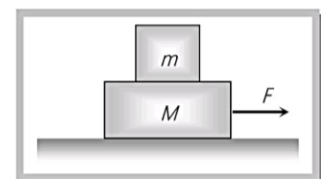

(d) $(M + m)(\mu_2 + \mu_1)g$

28. A block of mass M_1 is placed on a slab of mass M_2 . The slab lies on a frictionless horizontal surface. The coefficient of static friction between the block and slab is μ_1 and that of dynamic friction is μ_2 . A force F acts on the block M_1 . Take $g = 10 \text{ ms}^{-2}$. If $M_1 = 10 \text{ kg}$, $M_2 = 30 \text{ kg}$, $\mu_1 = 0.5$, $\mu_2 = 0.15$ and $F = 40 \text{ N}$, what will be the acceleration with which the slab will move

- (a) 5 ms^{-2}
(b) 2 ms^{-2}
(c) 1 ms^{-2}
(d) Zero

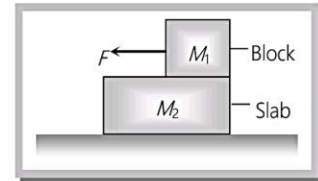

29. In the above problem if $F = 100 \text{ N}$, what will be the acceleration with which the slab will move

- (a) 5 ms^{-2} (b) 2 ms^{-2} (c) 1 ms^{-2} (d) None of these

30. A block X of mass 4 kg is lying on another block Y of mass 8 kg . As shown in the figure. When the force acting on X is 12 N , block X is on the verge of slipping on Y . The force F in Newton necessary to make both X and Y move simultaneously will be

- (a) 36
(b) 3.6
(c) 0.36
(d) 3.6

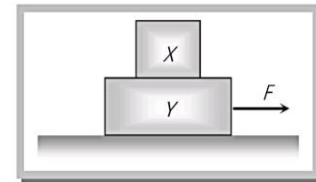

31. Two masses 10 kg and 5 kg are connected by a string passing over a pulley as shown. If the coefficient of friction be 0.15 , then the minimum weight that may be placed on 10 kg to stop motion is

- (a) 18.7 kg
(b) 23.3 kg
(c) 32.5 kg
(d) 44.3 kg

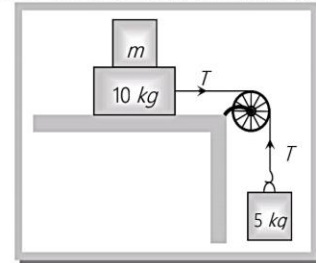

32. Two blocks of mass M_1 and M_2 are connected with a string which passes over a smooth pulley. The mass M_1 is placed on a rough inclined plane as shown in the figure. The coefficient of friction between the block and the inclined plane is μ . What should be the maximum mass M_2 so that block M_1 slides downward:

- (a) $M_2 = M_1(\sin \theta + \mu \cos \theta)$
(b) $M_2 = M_1(\sin \theta - \mu \cos \theta)$
(c) $M_2 = M_1 / (\sin \theta + \mu \cos \theta)$
(d) $M_2 = M_1 / (\sin \theta - \mu \cos \theta)$

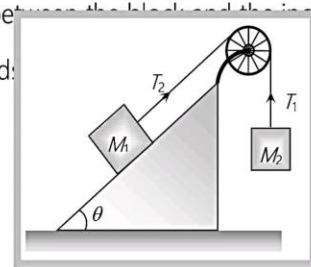

33. A car starts from rest to cover a distance s . the coefficient of friction between the road and the tyres is μ . The minimum time in which the car can cover the distance is proportional to
- (a) μ (b) $\sqrt{\mu}$ (c) $\frac{1}{\mu}$ (d) $\frac{1}{\sqrt{\mu}}$
34. An engine of mass $50,000 \text{ kg}$ pulls a coach of mass $40,000 \text{ kg}$. If there is a resistance of 1 N per 100 kg acting on both the engine and the coach, and if the driving force of the engine be $4,500 \text{ N}$, then the acceleration of the engine is
- (a) 0.08 m/s^2 (b) Zero (c) 0.04 m/s^2 (d) None of these
35. In the above question, then tension in the coupling is
- (a) $2,000 \text{ N}$ (b) $1,500 \text{ N}$ (c) 500 N (d) 1000 N
36. An aeroplane requires for take off a speed of 72 km/h . The run of the ground is 100 m . The mass of the plane is 10^4 kg and the coefficient of friction between the plane and the ground is 0.2 . The plane accelerates uniformly during take off. What is the acceleration of the plane
- (a) 1 m/s^2 (b) 2 m/s^2 (c) 3 m/s^2 (d) 4 m/s^2
37. The force required to just move a body up an inclined plane is double the force required to just prevent it from sliding down. If ϕ is angle of friction and θ is the angle which incline makes with the horizontal then
- (a) $\tan \theta = \tan \phi$ (b) $\tan \theta = 2 \tan \phi$ (c) $\tan \theta = 3 \tan \phi$ (d) $\tan \phi = 3 \tan \theta$
38. A body is on a rough horizontal plane. A force is applied to the body direct towards the plane at an angle ϕ with the vertical. If θ is the angle of friction then for the body to move along the plane
- (a) $\phi > \theta$ (b) $\phi < \theta$ (c) $\phi = \theta$ (d) ϕ can take up any value
39. In the arrangement shown $W_1 = 200 \text{ N}$, $W_2 = 100 \text{ N}$, $\mu = 0.25$ for all surfaces in contact. The block W_1 just slides under the block W_2

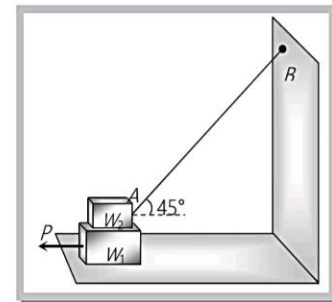

- (a) A pull of 50 N is to be applied on W_1
- (b) A pull of 90 N is to be applied on W_1
- (c) Tension in the string AB is $10\sqrt{2} \text{ N}$
- (d) Tension in the string AB is $20\sqrt{2} \text{ N}$
40. A board of mass m is placed on the floor and a man of mass M is standing on the board as shown. The coefficient of friction between the board and the floor is μ . The maximum force that the can exert on he rope so that the board does not slip on the floor is
- (a) $F = \mu(M + m)g$
- (b) $F = \mu mg$

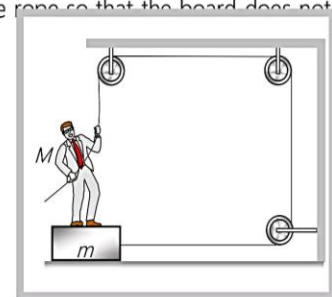

(c) $F = \frac{\mu Mg}{\mu + 1}$

(d) $F = \frac{\mu(M + m)g}{\mu + 1}$

41. A body slides over an inclined plane forming an angle of 45° with the horizontal. The distance x travelled by the body in time t is described by the equation $x = kt^2$, where $k = 1.732$. The coefficient of friction between the body and the plane has a value

- (a) $\mu = 0.5$ (b) $\mu = 1$ (c) $\mu = 0.25$ (d) $\mu = 0.75$

42. Two blocks A and B of masses m and M respectively are placed on each other and their combination rests on a fixed horizontal surface C . A light string passing over the smooth light pulley is used to connect A and B as shown. The coefficient of sliding friction between all surfaces in contact is μ . If A is dragged with a force F then for both A and B to move with a uniform speed we have

- (a) $F = \mu(M + m)g$
 (b) $F = \mu mg$
 (c) $F = \mu(3M + m)g$
 (d) $F = \mu(3m + M)g$

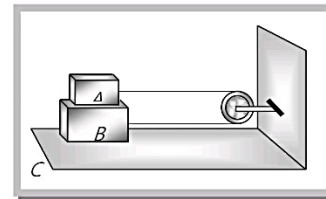

43. A force of 100 N is applied on a block of mass 3 kg as shown in figure. The coefficient of friction between the surface of the block is $1/4$. The friction force acting on the block is

- (a) 15 N downwards
 (b) 25 N upwards
 (c) 20 N downwards
 (d) 20 N upwards

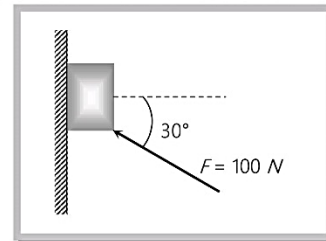

Answer Sheet (Practice problems)

1.	2.	3.	4.	5.	6.	7.	8.	9.	10.
b	c	d	d	b	a	c	a	c	b
11.	12.	13.	14.	15.	16.	17.	18.	19.	20.
c	c	a	d	d	c	a	b	c	d
21.	22.	23.	24.	25.	26.	27.	28.	29.	30.
a	c	a	a	c	d	d	c	d	a
31.	32.	33.	34.	35.	36.	37.	38.	39.	40.
b	b	d	c	a	b	c	a	b, d	d
41.	42.	43.							
a	d	c							